

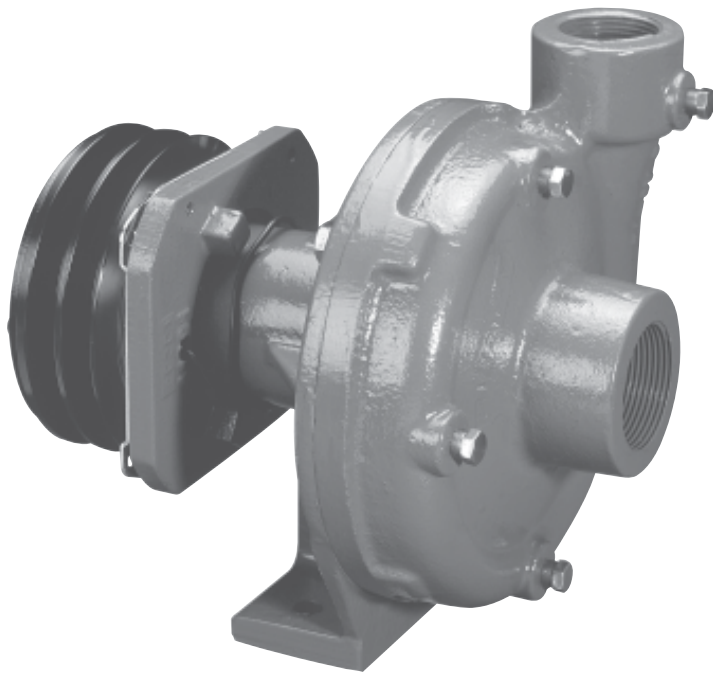

Heavy Duty SPRA-COUCPE® Centrifugal Pump

FMC-CW-150-MAG-DX3



- For **SPRA-COUCPE®** models:
3430 3440 3630 3640 4440 4640
- Suction 1-1/2" - Discharge 1-1/4"
- Clockwise Rotation when Facing Pulley End
- Chemical Resistant Valox® or Optional Cast Iron Impeller
- 3/4" Diameter Stainless Steel Shaft
- Standard Viton® Carbon/Ceramic seal or Optional Severe Duty Silicon Carbide Mechanical Seal
- Heavy Duty DC 12 Volt Magnetic Clutch Transmits up to 44 HP at 4000 RPM

Valox® is a registered trademark of GE Plastics.
Viton® is a registered trademark of DuPont Dow Elastomers.
Spra-Coupe® is a registered trademark of AGCO Corporation.

PERFORMANCE CHART

PUMP SHAFT RPM	20	30	40	60	80	100	MAX HP
	PSI GPM	PSI GPM	PSI GPM	PSI GPM	PSI GPM	PSI GPM	
3200	70 55	55 55	5 5	- -	- -	- -	1.4
3800	75 71	71 71	60 60	10 10	- -	- -	1.8
4400	80 78	78 78	72 72	60 60	- -	- -	3.0
5200	80 80	80 80	78 78	75 75	70 70	30 30	4.7

$$\frac{\text{Pump RPM}}{\text{Driveshaft RPM}} = \frac{\text{Drive Pulley Diameter}}{\text{Pump Pulley Diameter}}$$

Requires 5 Amp Fuse

FEATURE COMPARISON

Pump Feature	Ace Replacement	Original Equipment
Pump Bearings	204 Heavy Duty	202
Pump Shaft	3/4" Diameter	5/8" Diameter
Clutch Rating	58 ft.lbs.	30 ft.lbs.
Clutch Bearings	Two	One
Clutch Pulley	Machined Steel	Stamped Steel



FMC-CW-150-MAG-DX3

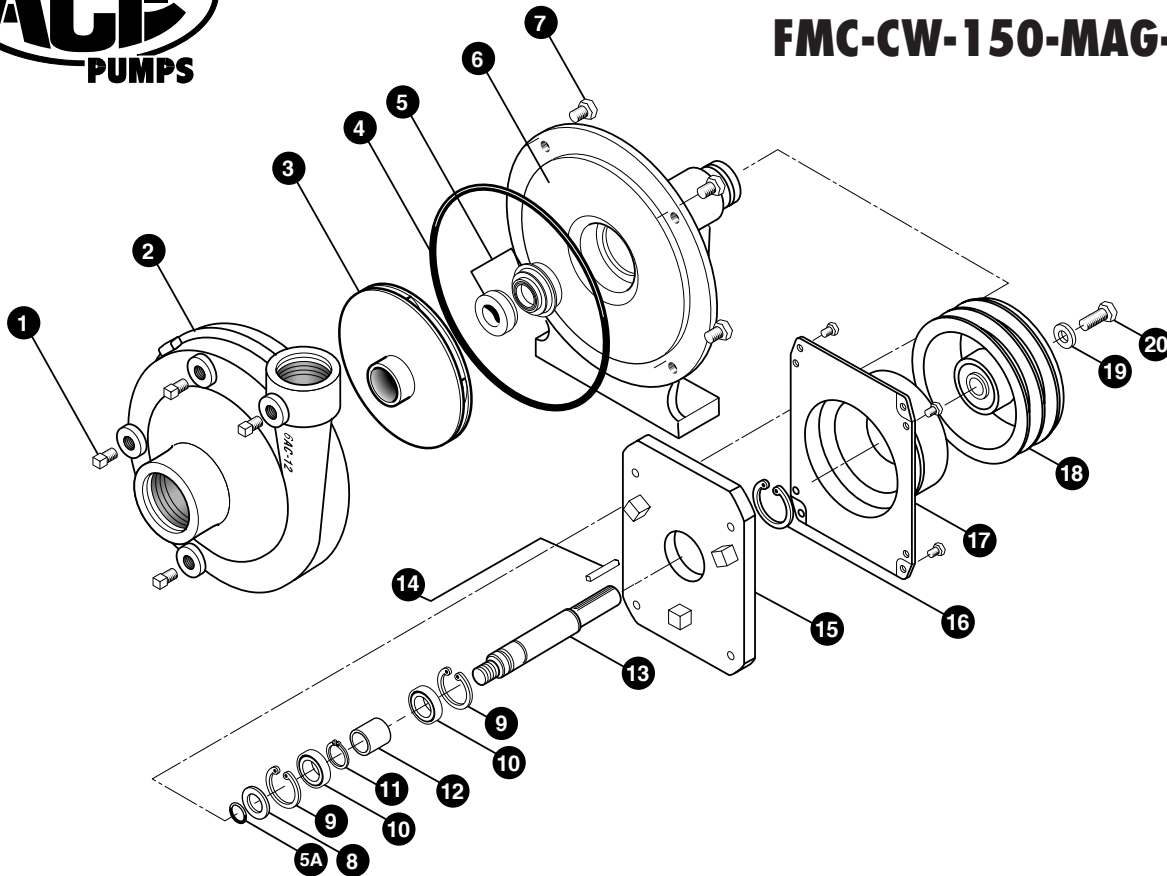

REF. #	PART #	EDP #	DESCRIPTION	REQ.
1	41110	41110	Pipe plug, 1/8" NPT	4
2	6AC-12	30130	Volute, 1-1/2" x 1-1/4", clockwise rotation, cast iron	1
3	BAC-26-CW-150-P	41510	Impeller, 5-1/2" dia., right hand NF thread, thermoplastic	1
4 [ⓐ]	BAC-4A	40005	"O" Ring for BAC-12 volute seal, effective Apr. '96	1
5 [ⓐ]	BAC-7V	40151	Seal, mechanical seal, Viton (includes 40160 "O" Ring)	1
5 [ⓑ]	BAC-7SC	40152	Seal, Silicon carbide mechanical seal (includes 40160 "O" Ring)(optional)	1
5A [ⓐ]	40160	40160	"O" Ring for BAC-6 shaft	1
6	BAC-14X3-MIA	40316	Mounting frame, -X series machined for idler arm	1
7	40950	40950	Cap screw, 3/8"NC x 3/4" Hex head	4
8	BAC-54	41130	Slinger	1
9	BAC-33X	40812	Snap ring, internal, BAC-14 mounting frame	2
10	BAC-37X	40872	Bearing, BAC-6 driven shaft	2
11	BAC-32X	40792	Snap ring, external, BAC-6 driven shaft	1
12	BAC-32X-S	40796	Spacer for BAC-6 shaft	1
13	BAC-6X-CW-D-SS	41507	Shaft, 5/8" Driven, -D clutch, right hand NF thread, stainless steel	1
14	BAC-50	41080	Key, 3/16" x 3/16" x 1-1/4"	1
15	41473	41473	Adapter plate, -D clutch, X Series	1
16	BAC-36X	40855	Snap ring, external, X series pump	1
17	41496	41496	Coil ring with 4 cap screws, - D clutch, 12 volt, DC activated	1
18	41497	41497	5" Pulley assy., -D clutch	1
19	41494	41494	Washer, -D clutch attachment	1
20	GE-60	42230	Cap Screw, 5/16" NF x 3/4", -D clutch attachment	1
①	RK-FMC	52700	Repair kit for FMC series with BAC-7V shaft seal	-
②	RK-FMCS	52706	Repair kit for FMC series with BAC-7SC shaft seal	-
#	41493	41493	Magnetic Clutch assembly, includes 41492, 41496, and 41497	-

ACE PUMP CORPORATION

P.O. Box 13187 • 1650 Channel Avenue • Memphis, TN 38113
 www.AcePumps.com • Phone: 901-948-8514 • Fax: 901-774-6147

Maximize the reliability and durability of your Spra-Coupe with an ACE Heavy Duty Centrifugal Pump. This powerful design delivers superior performance with minimal maintenance, when compared to it's closest industry competitors. ACE pumps' precision craftsmanship ensures the pump's dependability and longevity.

Heavy Duty 204 Bearings – 66% More Dynamic Load Capacity Than Original Equipment
 Ultra-Durable Double Bearing Clutch – 93% Higher Torque Rating Than Original Equipment
 Optional Severe Duty Controlled Porosity Silicon Carbide Seal

Dimension Drawing

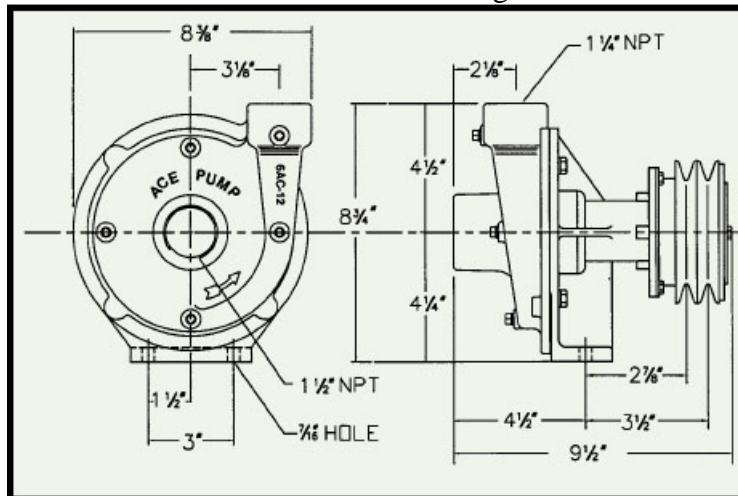

Performance Graph

